



## DC/DC 铁路机车整机工控电源

### JWDKR 铁路机车整机工控电源--150W 双路输出

JWDKR Railway locomotive Switching Power Supply--150W dual Output

#### 典型性能 Typical Performance

- ◆外形尺寸：200\*98\*40 (mm)  
Dimension: 200\*98\*40 (mm)
- ◆宽输入电压范围)  
Wide range input voltage
- ◆高效率、高功率密度、低纹波  
High efficiency、High power density、Low ripple & noise
- ◆105℃长寿命电解电容  
105℃ long life electrolytic capacitors
- ◆金属外壳，八面屏蔽，  
Metal shell, Eight face shield
- ◆安规：EN60950  
Ann rules: EN60950



#### 输入特性 Input Features

输入电压范围 Input voltage range	标称 110V Nominal voltage 110V	66~160VDC
	标称 72V Nominal voltage 72V	45~135VDC

#### 输出特性 Output Features

输出电压精度 Voltage tolerance	标称电压 Nominal voltage	$V_{O1} \leq \pm 1\%$ (3.3V、5V $\leq \pm 2\%$ ), $V_{O2} \leq \pm 5\%$
电压调整率 Line regulation (full load)	输入电压从低端到高端变化 Change of input voltage from lowend to highend	$V_{O1} \leq \pm 0.5\%$ , $V_{O2} \leq \pm 1.5\%$
负载调整率 Load regulation	20%~100%负载变化 20%~100% Load change	$V_{O1} \leq \pm 0.5\%$ , $V_{O2} \leq \pm 3\%$
温度系数 Temperature coefficient		$\pm 0.02\%/^{\circ}\text{C}$
过功率保护 Output overload Protection		115~150%额定功率,自恢复 115~150%rated output power,auto recovery
短路保护 Short Circuit Protection		长期, 自恢复 Long-term,auto recovery
过冲幅度 Overshoot	25%额定负载变化 25% rated load change	$\leq 500\mu\text{S}$
	$\Delta V_{O1} / V_{O1}$	$\leq \pm 4.0\%$

#### 一般特性 General Features

隔离耐压 Withstand voltage	输入对输出、输入对地 I/P-O/P、I/P-F/G	1500VAC
	输入对地 I/P-F/G	500VAC
	输出对输出(隔离) O/P-O/P( (1分钟,漏电流 $\leq 5\text{mA}$ ) (1Minute leakage current) $\leq 5\text{mA}$ )	500VDC
绝缘电阻 Isolation resistance	500V	$\geq 50\text{M}\Omega$
MTBF	环境 25℃ Environment 25℃	$2.0 \times 10^5 \text{Hrs}$
工作温度 Operating temperature	55℃以上降额使用 Above 55℃ derating make	-40℃~70℃
储存温度 Storage temperature		-40℃~85℃
工作相对湿度 Operating humidity	无凝露及结冰现象 (non condensing)	10%~90%RH
储存相对湿度 Storage humidity	无凝露及结冰现象 (non condensing)	5%~95%RH
冷却方式 Cooling method		自然冷却 Convection

## 命名方式 Naming Rules

### JWDKR150-110 D 5

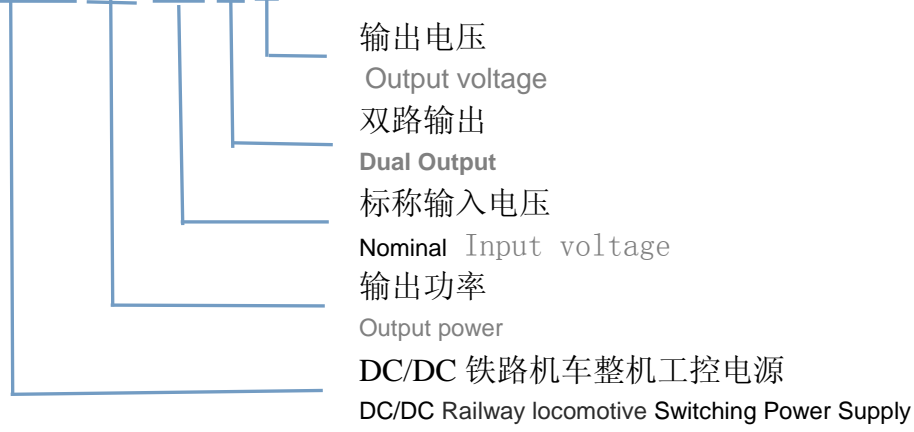

### JWDKR150-110 S5 S12 I

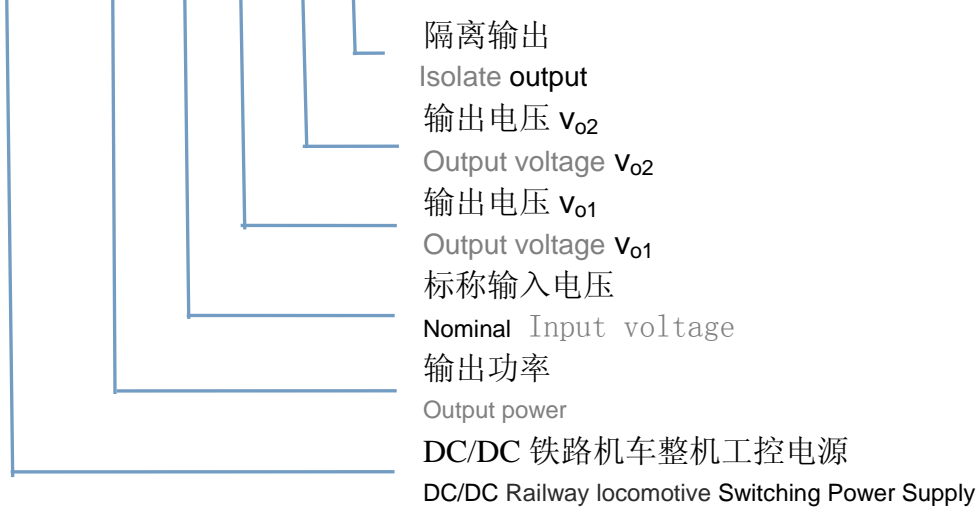

## 产品选型 Product selection

产品型号 Model No.	输入电压 Input voltage V <sub>in</sub>	输出电压 Output voltage V <sub>o</sub>	输出电流 Output current I <sub>o</sub>	输出电压精度 Output voltage tolerance	纹波噪声 R&N V <sub>(P-P)mV</sub>	效率 Efficiency
JWDKR150-110D5	66~160V	+5V	2.0~15A	±2%	80mV	78%
		-5V	2.0~15A	±5%	100mV	
JWDKR150-110D12		+12V	0.6~6.3A	±1%	120mV	83%
		-12V	0.6~6.3A	±3%	120mV	
JWDKR150-110D24		+24V	0.3~3.2A	±1%	150mV	86%
		-24V	0.3~3.2A	±3%	150mV	
JWDKR150-110S5S5I		+5V	2.0~20.0A	±2%	100mV	78%
		+5V	1.0~10.0A	±5%	100mV	
JWDKR150-110S5S12I		+5V	2.0~15.0A	±2%	80mV	80%
		+12V	0.6~6.0A	±6%	120mV	
JWDKR150-110S12S12I		+12V	1.0~10.0A	±1%	120mV	82%
		+12V	0.6~6.0A	±5%	100mV	
JWDKR150-110S12S24I		+24V	0.5~5.0A	±1%	150mV	84%
		+5V	2.0~15A	±2%	80mV	
JWDKR150-72D5	45~135V	+5V	2.0~15A	±2%	80mV	78%
		-5V	2.0~15A	±5%	100mV	
JWDKR150-72D12		+12V	0.6~6.3A	±1%	120mV	83%
		-12V	0.6~6.3A	±3%	120mV	
JWDKR150-72D24		+24V	0.3~3.2A	±1%	150mV	86%
		-24V	0.3~3.2A	±3%	150mV	
JWDKR150-72S5S5I		+5V	2.0~20.0A	±2%	100mV	78%
		+5V	1.0~10.0A	±5%	100mV	
JWDKR150-72S5S12I		+5V	2.0~15.0A	±2%	80mV	80%
		+12V	0.6~6.0A	±6%	120mV	
JWDKR150-72S12S12I		+12V	1.0~10.0A	±1%	120mV	82%
		+12V	0.6~6.0A	±5%	100mV	
JWDKR150-72S12S24I		+24V	0.5~5.0A	±1%	150mV	84%
		+5V	0.5~5.0A	±5%	100mV	

注：1、纹波噪声测试方法：使用一根12”双绞线，在终端并联0.1uF和47uF电容，在20MHz带宽下测试。

2、因篇幅有限，以上只是部分产品列表，若需列表以外产品，请与本公司销售部联系。

Note: 1、Ripple & noise are measured at 20MHz of bandwidth by using a 12”twisted pair-wire terminated with a 0.1uF & 47uF parallel capacitor.

2、Due to space limitations, the above list is only for some products, If other than a list of products, please contact the Company's sales department..

安装尺寸图 Mechanical Data

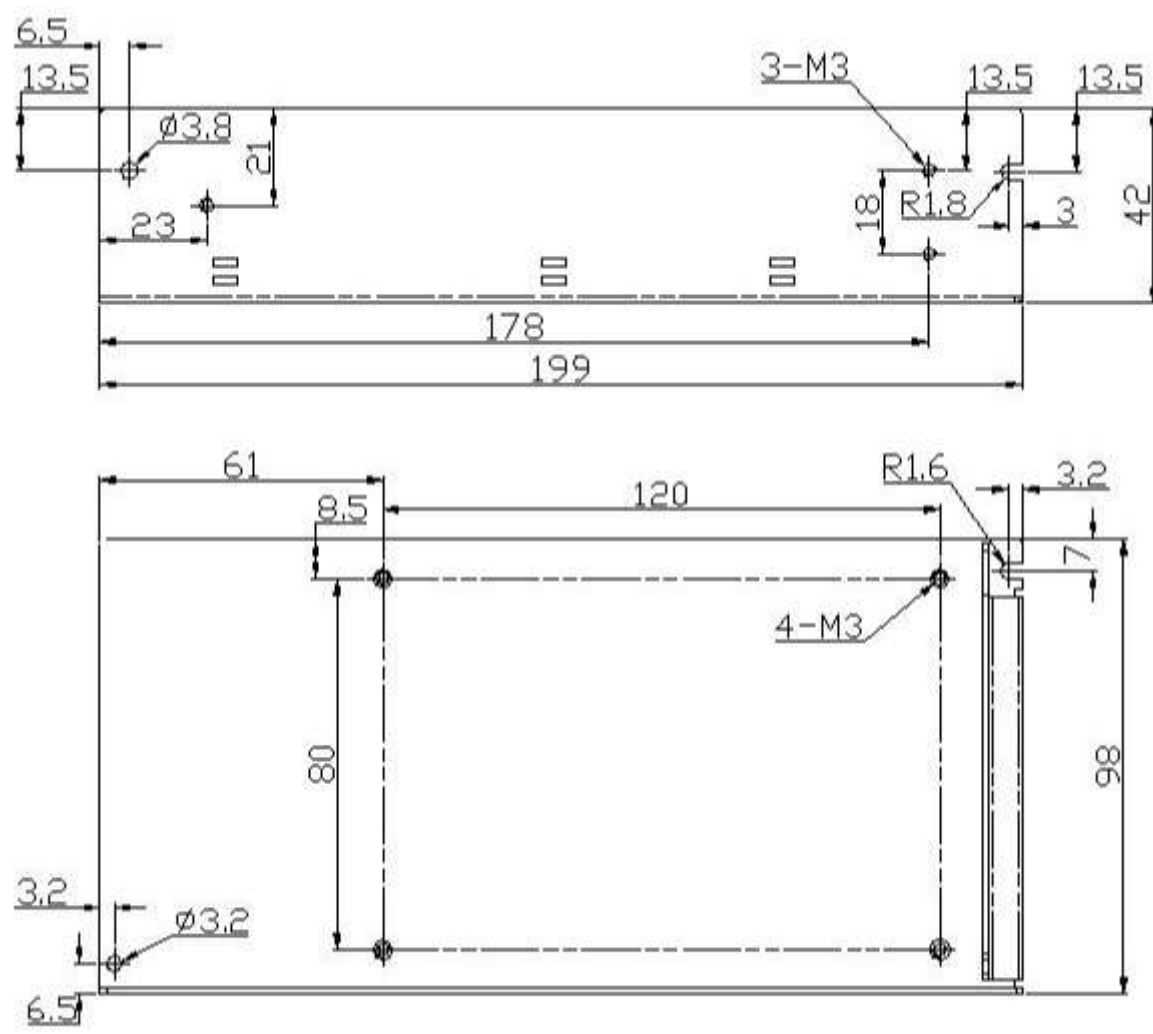

注：电源安装尺寸如与选型手册不符，应以实物标签上的标注为准。

Note: Power mechanical data does not match with the hand book, please refer to the actual item.