



## AC/DC 整机工控电源

### JWAK 高压输入整机工控电源系列--100W 三路输出

JWAK Switching Power Supply Series With High Voltage Input --100W Triple Output

#### 典型性能 Typical Performance

- ◆外形尺寸: 200\*98\*40 (mm)  
Dimension: 200\*98\*40 (mm)
- ◆宽输入电压范围  
Wide range input voltage
- ◆高效率、高功率密度、低纹波  
High efficiency、High power density、Low ripple & noise
- ◆105℃长寿命电解电容  
105℃ long life electrolytic capacitors
- ◆高可靠性、三年保修  
High reliability、three-year warranty
- ◆安规: EN60950  
Ann rules: EN60950



#### 输入特性 Input Features

输入电压范围 Input voltage range	:265~450VAC 370~635VDC	380VAC
输入电压频率 Input voltage frequency		47~63Hz
输入冲击电流 Inrush current	380VAC 冷启动 380VAC Cold start,	≅ 40A

#### 输出特性 Output Features

输出电压精度 Voltage tolerance	标称电压 Nominal voltage	$V_{O1} \cong \pm 1\%$ (3.3V、5V $\cong \pm 2\%$ ), $V_{O2}$ 、 $V_{O3} \cong \pm 5\%$
电压调整率 Line regulation (full load)	输入电压从低端到高端变化 Change of input voltage from lowend to highend	$V_{O1} \cong \pm 0.5\%$ $V_{O2}$ 、 $V_{O3} \cong \pm 1.5\%$
负载调整率 Load regul	20%~100%负载变化 20%~100% Load change	$V_{O1} \cong \pm 0.5\%$ , $V_{O2} \cong \pm 3\%$ , $V_{O3} \cong \pm 5\%$
温度系数 Temperature coefficient		$\pm 0.02\%/^{\circ}\text{C}$
过功率保护 Output overload Protection		115~150%额定电流,自恢复 115~150%rated output powerI,auto recovery
短路保护 Short Circuit Protection		长期,自恢复 Long-term,auto recovery
效率 Efficiency	输入标称电压、满载 Input rated voltage、pullload	80% (典型值) 80%(typical)
启动时间 Rise time	380VAC 满载 380VAC Fullload	100mS (典型值) 100ms (typical)
保持时间 Hold up time	380VAC 满载 380VAC Full oad	20mS (典型值) 20ms (typical)

#### 一般特性 General Features

隔离耐压 Withstand voltage	输入对输出、输入对地 I/P-O/P、I/P-F/G 输出对地 O/P -F/G 输出对输出(隔离) O/P-O/P( (1分钟,漏电流 $\cong 5\text{mA}$ ) (1Mintute leakage current) $\cong 5\text{mA}$ )	1500VAC  500VAC  500VDC
绝缘电阻 Isolation resistance	500V	$\cong 50\text{M}\Omega$
MTBF	环境 25℃ Environment 25℃	$2.0 \times 10^5$ Hrs
工作温度 Operating temperature	55℃以上降额使用 Above 55℃ derating make	-25℃~70℃(-40℃~70℃)
储存温度 Storage temperature		-40℃~85℃
工作相对湿度 Operating humidity	无凝露及结冰现象 (non condensing)	10%~90%RH
储存相对湿度 Storage humidity	无凝露及结冰现象 (non condensing)	5%~95%RH
冷却方式 Cooling method		自然冷却 Convection

**命名方式** Naming Rules

**JWAK-100S5 D12 G I**

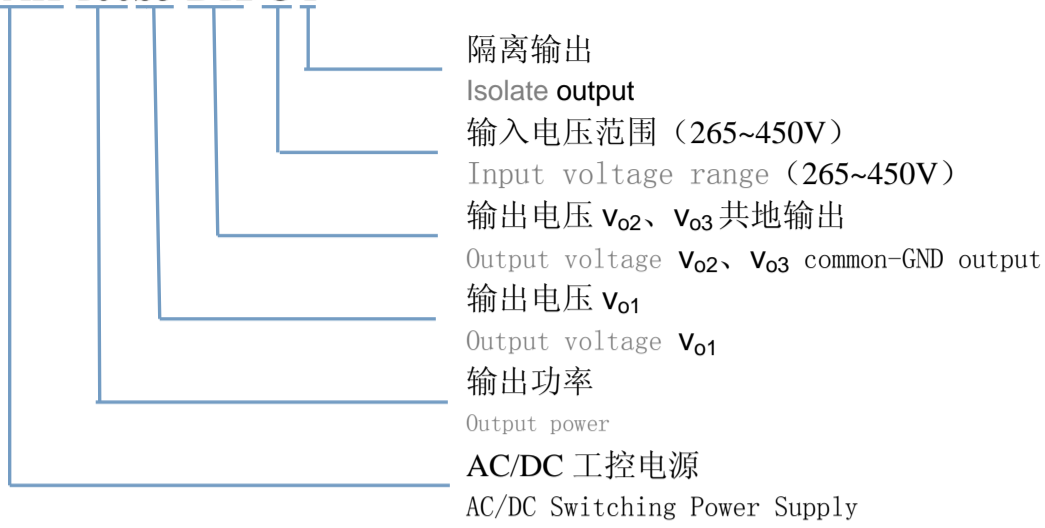

**JWAK-100S5 S12 S24 G I**

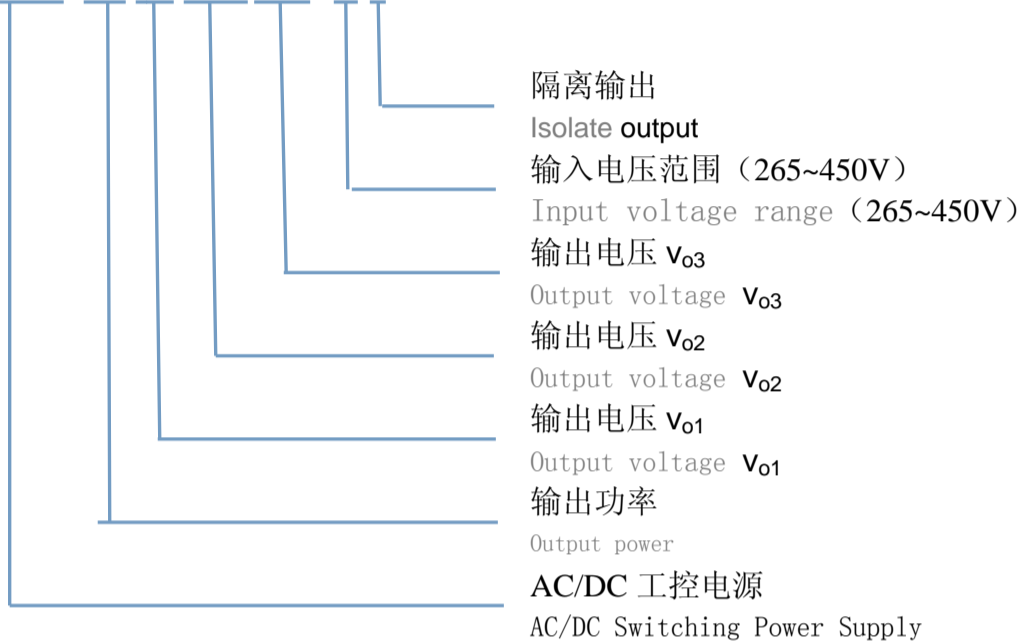

**产品选型** Product Selection Table

产品型号 Model No.	输出电压 Output voltage $V_O$	输出电流 Output current $I_O$	输出电压精度 Output voltage tolerance	纹波噪声 R&N $V_{(P-P)mV}$	效率 Efficiency
JWAK-100S5D5GI	+5V	3.0~15.0A	±2%	100mV	76%
	+5V	0.4~4.0A	±5%	100mV	
	-5V	0.12~1.0A	±5%	100mV	
JWAK-100S5D12GI	+5V	2.0~10.0A	±2%	100mV	80%
	+12V	0.4~4.0A	±6%	120mV	
	-12V	0.1~0.5A	±5%	120mV	
JWAK-100S5D15GI	+5V	2.0~10.0A	±2%	100mV	81%
	+15V	0.4~3.0A	±5%	150mV	
	-15V	0.1~0.5A	±5%	150mV	
JWAK-100S12D5GI	+12V	1.0~7.0A	±1%	120mV	79%
	+5V	0.2~2.0A	±5%	100mV	
	-5V	0.1~1.0A	±5%	100mV	
JWAK-100S24D5GI	+24V	0.2~3.5A	±1%	200mV	80%
	+5V	0.2~2.0A	±5%	100mV	
	-5V	0.1~1.0A	±5%	100mV	
JWAK-100S5S12S24GI	+5V	2.0~10.0A	±2%	100mV	84%
	+12V	0.1~0.6A	±5%	120mV	
	+24V	0.4~2.0A	±5%	200mV	
JWAK-100S5S12S-5GI	+5V	0.6~5.0A	±2%	100mV	79%
	+12V	0.1~1.5A	±5%	120mV	
	-5V	0.1~1.0A	±5%	100mV	

注：1、纹波噪声测试方法：使用一根 12” 双绞线，在终端并联 0.1uF 和 47uF 电容，在 20MHz 带宽下测试。

2、因篇幅有限，以上只是部分产品列表，若需列表以外产品，请与本公司销售部联系。

Note: 1、Ripple & noise are measured at 20MHz of bandwidth by using a 12”twisted pair-wire terminated with a 0.1uF & 47uF parallel capacitor

2、Due to space limitations ,the above list is only for some products, If other than a list of products, please contact the Company's sales department.

安装尺寸图 Mechanical Data

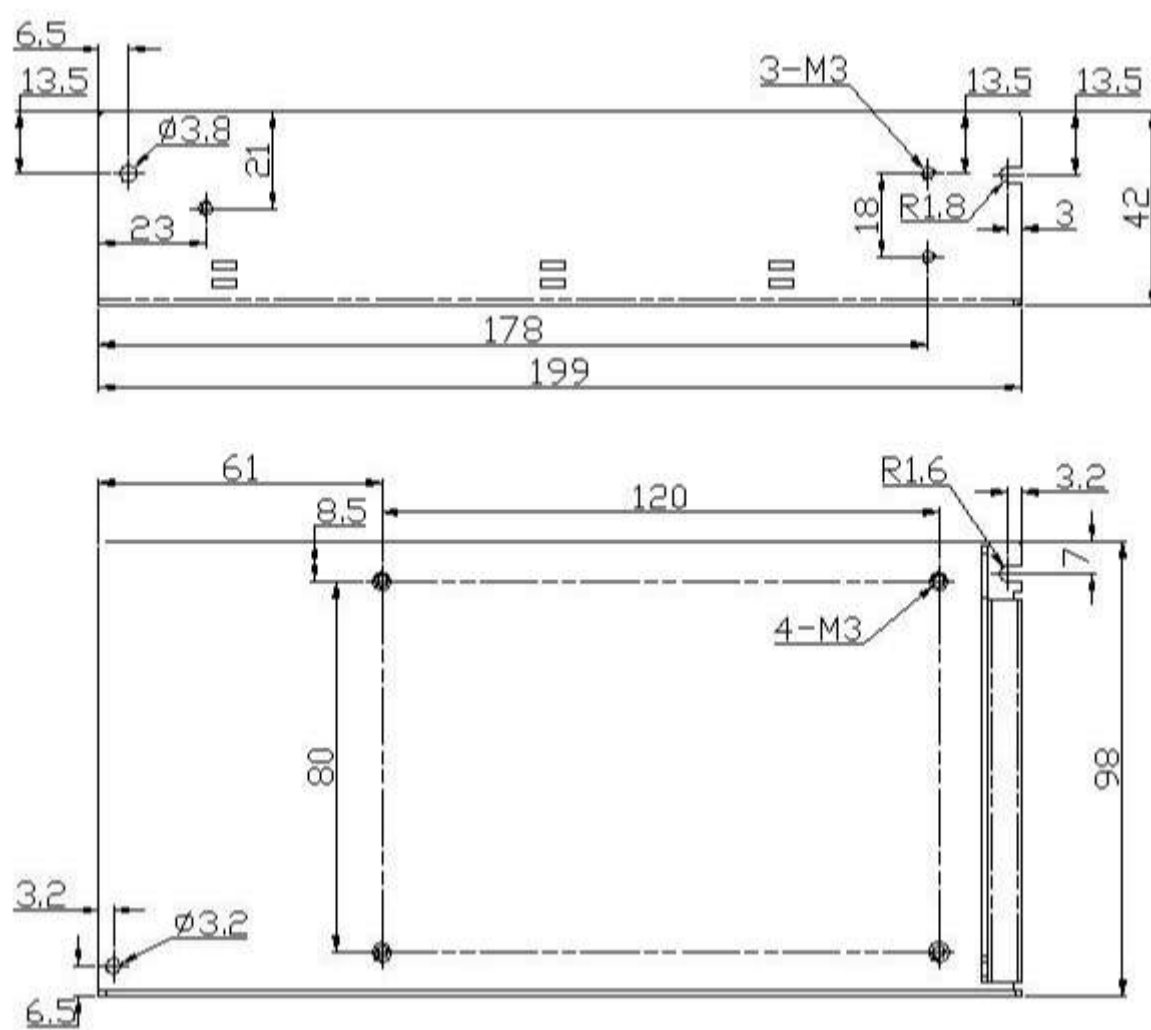

注：电源安装尺寸如与选型手册不符，请以实物尺寸为准。

Note: Power mechanical data does not match with the hand book, Please refer to product size.