



DC/DC 整机工控电源

JWDC 整机工控电源系列--100W 单路输出

JWDC Switching Power Supply Series--100W Single Output

典型性能 Typical Performance

- ◆外形尺寸: 200*98*40 (mm)
Dimension: 200*98*40 (mm)
- ◆宽输入电压范围 (2: 1 输入电压范围)
Wide range input voltage (2: 1 range input voltage)
- ◆高效率、高功率密度、低纹波
High efficiency、High power density、Low ripple & noise
- ◆105°C长寿命电解电容
105°C long life electrolytic capacitors
- ◆高可靠性、三年保修
High reliability、three-year warranty
- ◆安规: EN60950
Ann rules: EN60950



输入特性 Input Features

输入电压范围 Input voltage range	标称 24V Nominal voltage 24V 标称 48V Nominal voltage 48V 标称 110V Nominal voltage 110V	18~36VDC 36~72VDC 72~1440VDC
-------------------------------	---	--

输出特性 Output Features

输出电压精度 Voltage tolerance	标称电压 Nominal voltage	$\leq \pm 1\%$ (3.3V、5V $\leq \pm 2\%$)
电压调整率 Line regulation	输入电压从低端到高端变化 Change of input voltage from lowend to highend	$\leq \pm 0.5\%$
可调范围 Adjustment range		$\pm 10\%$
负载调整率 Load regul	20%~100%负载变化 20%~100% Load change	$V_O \leq \pm 0.5\%$
纹波噪声 Ripple&Noise	20M 带宽 20M Bandwidth	$\leq 1\%$
温度系数 Temperature coefficient		$\pm 0.02\%/^{\circ}\text{C}$
过流保护 Output overcircuit Protection		115~150%额定电流,自恢复 115~150%rated output circuit, auto recovery
短路保护 Short Circuit Protection		长期, 自恢复 Long-term, auto recovery
过冲幅度 Overshoot	25% 额定负载变化 25% rated load change	$\leq 25\mu\text{S}$
	$\Delta V_{O1}/V_{O1}$	$\leq \pm 5.0\%$

一般特性 General Features

隔离耐压 Withstand voltage	输入对输出、输入对地 I/P-O/P、I/P-F/G 输出对地 O/P-F/G (1分钟, 漏电流 $\leq 5\text{mA}$) (1Mintute ,leakage current) $\leq 5\text{mA}$)	1500VAC 500VAC
绝缘电阻 Isolation resistance	500V	$\geq 50\text{M}\Omega$
MTBF	环境 25°C Environment 25°C	$2.0 \times 10^5 \text{Hrs}$
工作温度 Operating temperature	55°C以上降额使用 Above 55°C derating make	-25°C~70°C(-40°C~70°C)
储存温度 Storage temperature		-40°C~85°C
工作相对湿度 Operating humidity	无凝露及结冰现象 (non condensing)	10%~90%RH
储存相对湿度 Storage humidity	无凝露及结冰现象 (non condensing)	5%~95%RH
冷却方式 Cooling method		自然冷却 Convection

命名方式 Naming Rules

JWDK100- 24 S 5

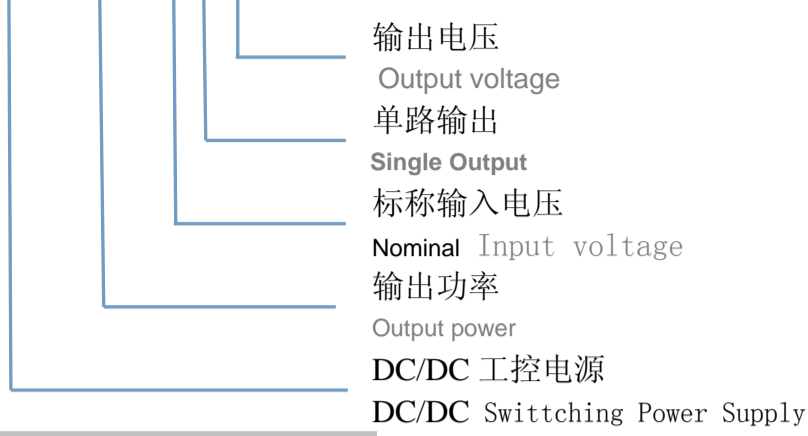

产品选型 Product selection

产品型号 Model No.	输入电压范围 Input voltage V_{in}	输出电压 Output voltage V_O	输出电流 Output current I_o	纹波噪声 R & N $V_{(P-P)mV}$	效率 Efficiency
JWDK100--24S5	18~36V	5V	20.0A	100	76%
JWDK100--24S12		12V	8.3A	120	82%
JWDK100--24S15		15V	6.7A	120	83%
JWDK100--24S24		24V	4.2A	150	85%
JWDK100--48S5	36~72V	5V	20.0A	100	77%
JWDK100--48S12		12V	8.3A	120	83%
JWDK100--48S15		15V	6.7A	120	84%
JWDK100--48S24		24V	4.2A	150	85%
JWDK100--110S5	72~144V	5V	20.0A	100	78%
JWDK100--110S12		12V	8.3A	120	82%
JWDK100--110S15		15V	6.7A	120	83%
JWDK100--110S24		24V	4.2A	150	85%

注：1、纹波噪声测试方法：使用一根 12” 双绞线，在终端并联 0.1uF 和 47uF 电容，在 20MHz 带宽下测试。

2、因篇幅有限，以上只是部分产品列表，若需列表以外产品，请与本公司销售部联系。

Note: 1、Ripple & noise are measured at 20MHz of bandwidth by using a 12”twisted pair-wire terminated with a 0.1uF & 47uF parallel capacitor

2、Due to space limitations ,the above list is only for some products, If other than a list of products, please contact the Company's sales department.

安装尺寸图 Mechanical Data

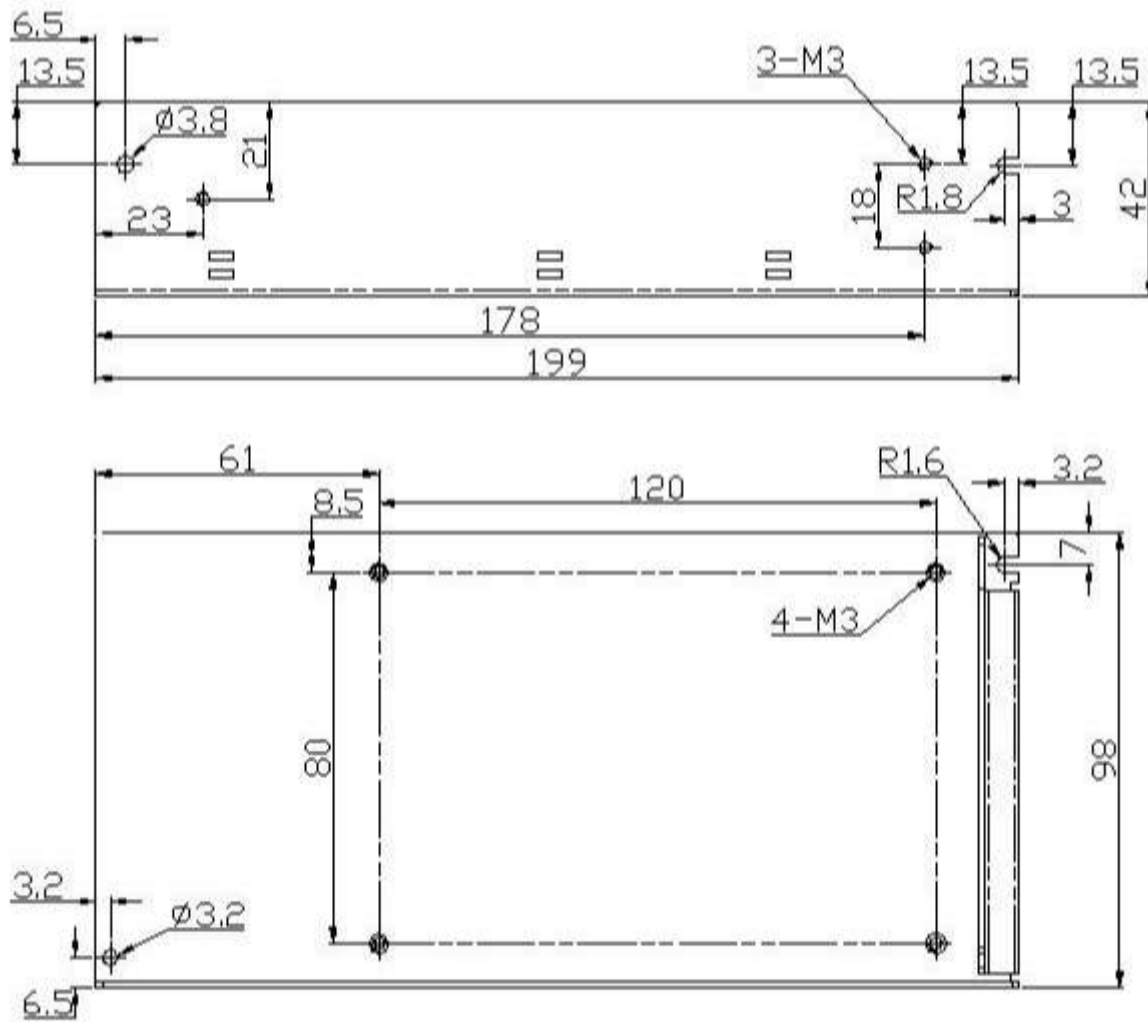

注：电源安装尺寸如与选型手册不符，请以实物尺寸为准。

Note: Power mechanical data does not match with the hand book, Please refer to product size.