



AC/DC 整机工控电源

JWAK 整机工控电源系列--100W 四路输出

JWAK Switching Power Supply Series--100W Quade Output

典型性能 Typical Performance

- ◆外形尺寸: 200*98*40 (mm)
Dimension: 200*98*40 (mm)
- ◆宽输入电压范围
Wide range input voltage
- ◆高效率、高功率密度、低纹波
High efficiency、High power density、Low ripple & noise
- ◆105℃长寿命电解电容
105℃ long life electrolytic capacitors
- ◆高可靠性、三年保修
High reliability、three-year warranty
- ◆安规: EN60950
Ann rules: EN60950



输入特性 Input Features

输入电压范围 Input voltage range	W:85~265VAC 120~370VDC N:165~265VAC 230~370VDC	110VAC 220VAC
输入电压频率 Input voltage frequency		47~63Hz
输入冲击电流 Inrush current	230VAC 冷启动 230VAC Cold start,	≦40A

输出特性 Output Features

输出电压精度 Voltage tolerance	标称电压 Nominal voltage	$V_{O1} \leq \pm 1\%$ (3.3V、5V $\leq \pm 2\%$), V_{O2} 、 $V_{O3} \leq \pm 3\%$, $V_{O4} \leq \pm 6\%$
电压调整率 Line regulation (full load)	输入电压从低端到高端变化 Change of input voltage from lowend to highend	$V_{O1} \leq \pm 0.5\%$, V_{O2} 、 V_{O3} 、 $V_{O4} \leq \pm 1.5\%$
负载调整率 Load regul	20%~100%负载变化 20%~100% Load change	$V_{O1} \leq \pm 0.5\%$, V_{O2} 、 $V_{O3} \leq \pm 3\%$, $V_{O4} \leq \pm 6\%$
温度系数 Temperature coefficient		$\pm 0.02\%/^{\circ}\text{C}$
过功率保护 Output overload Protection		115~150%额定电流,自恢复 115~150%rated output power!, auto recovery
短路保护 Short Circuit Protection		长期, 自恢复 Long-term, auto recovery
效率 Efficiency	输入标称电压、满载 Input rated voltage、Full load	75% (典型值) 75%(typical)
启动时间 Rise time	220VAC 满载 220VAC Full load	1000mS (典型值) 1000ms (typical)
保持时间 Hold up time	220VAC 满载 220VAC Full load	30mS (典型值) 30ms (typical)

一般特性 General Features

隔离耐压 Withstand voltage	输入对输出、输入对地 I/P-O/P、I/P-F/G 输出对地 O/P -F/G 输出对输出(隔离) O/P-O/P((1分钟, 漏电流 $\leq 5\text{mA}$) (1Mintute leakage current) $\leq 5\text{mA}$)	1500VAC 500VAC 500VDC
绝缘电阻 Isolation resistance	500V	$\geq 50\text{M}\Omega$
MTBF	环境 25℃ Environment 25℃	2.0×10^5 Hrs
工作温度 Operating temperature	55℃以上降额使用 Above 55℃ derating make	-25℃~70℃(-40℃~70℃)
储存温度 Storage temperature		-40℃~85℃
工作相对湿度 Operating humidity	无凝露及结冰现象 (non condensing)	10%~90%RH
储存相对湿度 Storage humidity	无凝露及结冰现象 (non condensing)	5%~95%RH
冷却方式 Cooling method		自然冷却 Convection

命名方式 Naming Rules

JWAK-100 S5 D12 S24 N I

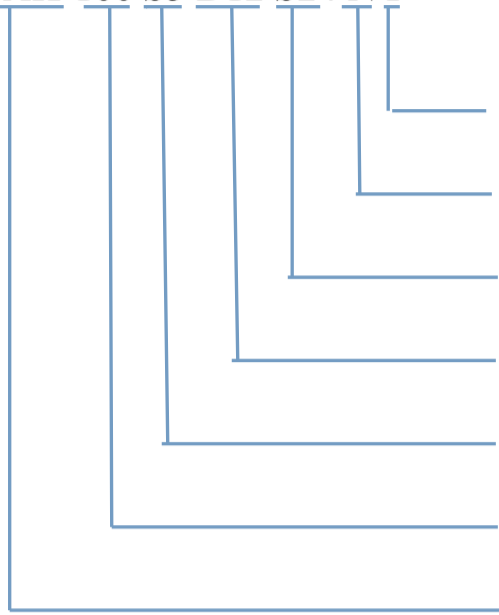

隔离输出
Isolate output
输入电压范围 (N:165~265V)
Input voltage range (N:165~265V)
输出电压 V₀₄
Output voltage V₀₄
输出电压 V₀₂、V₀₃ 共地输出
Output voltage V₀₂、V₀₃ common-GND output
输出电压 V₀₁
voltage V₀₁
输出功率
Output power
AC/DC 工控电源
AC/DC Switching Power Supply

产品选型 Product Selection Table

产品型号 Model No.	输出电压 Output voltage V ₀	输出电流 Output current I ₀	输出电压精度 Output voltage tolerance	纹波噪声 R&N V (P-P)mV	效率 Efficiency
JWAK-100S5D12S-5NI	+5V	1.0~10.0A	±2%	100mV	78%
	+12V	0.2~2.0A	±6%	120mV	
	-12V	0.1~1.0A	±6%	120mV	
	-5V	0.3~3.0A	±5%	100mV	
JWAK-100S5D12S24NI	+5V	0.6~6.0A	±2%	100mV	80%
	+12V	0.2~2.0A	±6%	120mV	
	-12V	0.2~1.0A	±5%	120mV	
	+24V	0.2~1.5A	±6%	150mV	
JWAK-100S5D12S12NI	+5V	0.6~6.0A	±2%	100mV	79%
	+12V	0.2~2.0A	±6%	120mV	
	-12V	0.2~1.0A	±5%	100mV	
	+12V	0.2~2.0A	±5%	100mV	
JWAK-100S5D12S15NI	+5V	0.6~6.0A	±2%	100mV	79%
	+12V	0.2~2.0A	±6%	120mV	
	-12V	0.2~1.0A	±5%	120mV	
	+15V	0.1~1.0A	±5%	120mV	
JWAK-100S5D15S-5NI	+5V	1.0~8.0A	±2%	100mV	79%
	+15V	0.4~2.0A	±6%	150mV	
	-15V	0.1~1.0A	±5%	120mV	
	-5V	0.3~3.0A	±5%	100mV	
JWAK-100S5D15S24NI	+5V	0.6~6.0A	±2%	100mV	80%
	+15V	0.2~2.0A	±6%	150mV	
	-15V	0.2~1.0A	±5%	120mV	
	24V	0.1~1.0A	±5%	100mV	

注：1、纹波噪声测试方法：使用一根 12” 双绞线，在终端并联 0.1uF 和 47uF 电容，在 20MHz 带宽下测试。

2、因篇幅有限，以上只是部分产品列表，若需列表以外产品，请与本公司销售部联系。

Note: 1、Ripple & noise are measured at 20MHz of bandwidth by using a 12”twisted pair-wire terminated with a 0.1uF & 47uF parallel capacitor

2、Due to space limitations ,the above list is only for some products, If other than a list of products, please contact the Company's sales department.

安装尺寸图 Mechanical Data

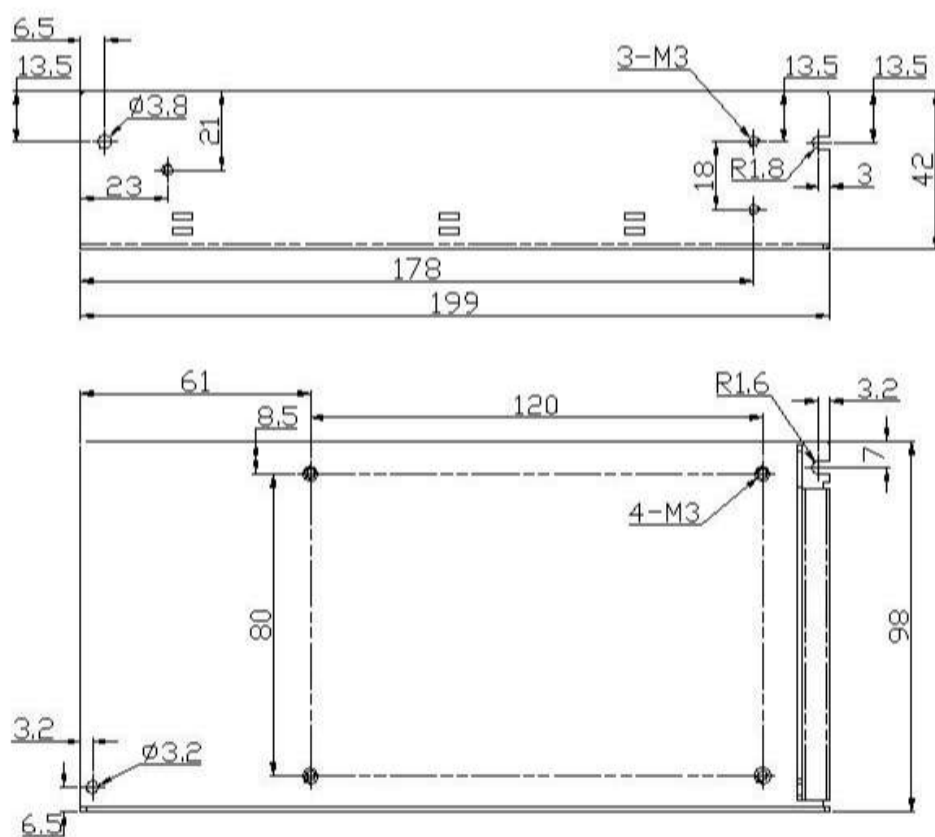

注：电源安装尺寸如与选型手册不符，请以实物尺寸为准。

Note: Power mechanical data does not match with the hand book, Please refer to product size.